

# TASCAM®

4-Channel Mic/Line Input Dante Converter with built-in DSP Mixer

EuroBlock Model **MM-4D/IN-E**

XLR Model **MM-4D/IN-X**



## Dante Compact Processor series

Providing versatility, flexibility and expandability by combining multiple DCP units.

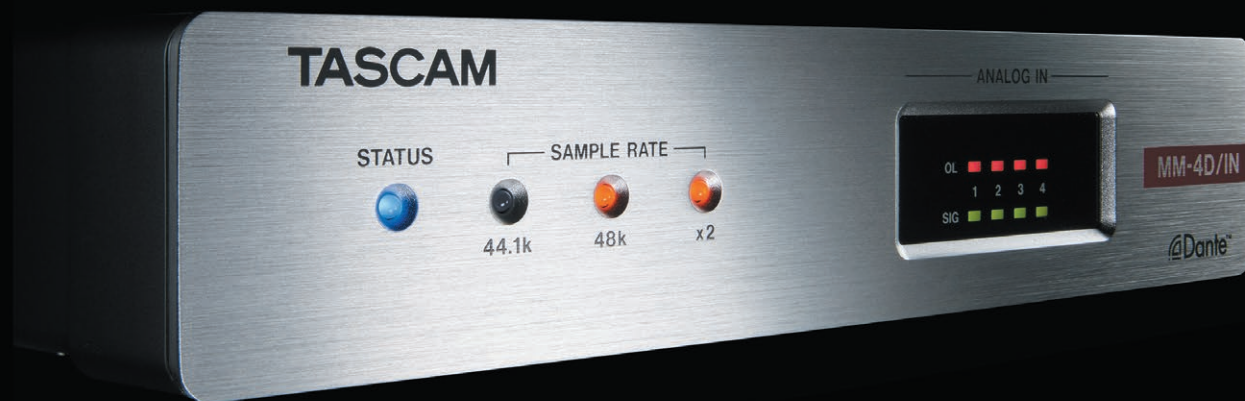

Built-in DSP 4 Mic/Line input Dante converter to respond to various needs of contractor market and professional audio scene.

Dante  
4x4

Compatible with Dante Domain Manager, and Dante AES67 Mode

MIC/LINE  
In x4

Supports +48V Phantom power

24-bit  
96kHz

PoE  
Power on Ethernet

Remote Mic  
Gain Control

on-Board  
DSP

8 IN/4 OUT  
Matrix Mixer





## Compact 1U half-rack size processor series for Dante system

The MM-4D/IN is compact converter that converts 4-channel Mic/Line input signals into Dante signals. With half the size of a standard 1U rack, the MM-4D/IN is suitable for different Dante systems as an exquisite analog output unit. The built-in DSP mixer enables small scale systems to fully perform with a variety of input/output models the TASCAM Dante Compact Processor Series offers. MM-4D/IN supports up to 96kHz/24bit and uses Euroblock connectors for analog Mic/Line input/output. Available with EuroBlock connector model (MM-4D/IN-E) and XLR connector model (MM-4D/IN-X).

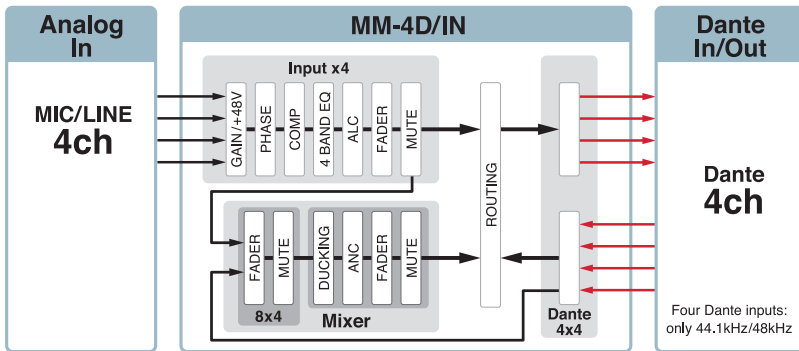

### Phantom power and remote gain control compatible Mic pre-amps

The installed Mic pre-amps support phantom power (+48V) and the input gain can be remote controlled via TASCAM DCP CONNECT software, via Dante or other external controllers.

### TASCAM studio quality Mic pre-amps installed

The MM-4D/IN has installed two natural-sounding, high grade TASCAM mic preamps made with all the knowledge and experience cultivated through the years in the making of pro audio equipment. Input range covers from -74 dBu to +26 dBu, with equivalent input noise achieving less than -125 dB, and signal-noise ratio over 105 dB.

### Compressor, 4 parametric EQ, auto level, and more effects included

They can be finely adjusted depending on the Mic/Line equipment used.



Compressor



4 Parametric EQ

### Built-in 8 in / 4 out matrix mixer

Using the built-in matrix mixer, users can mix up to 8 different sources (4-channel Mic/Line inputs with 4-channel Dante inputs) and configure the settings on each of the four output zones. The matrix mixer is also equipped with a ducking function and an ambient noise compensator function, which detects the level of environmental sounds and automatically adjusts the input level of the source.



### Input/output routing

Flexible routing allows users to choose the output zone of 4 Mic/Line inputs or the built-in matrix mixer output zone as 4 Dante output. The MM-4D/IN can also be used as a simple Mic/Line input unit by bypassing the matrix mixer.



## EuroBlock Model **MM-4D/IN-E** 4-ch Mic/Line Input Dante Converter with built-in DSP Mixer

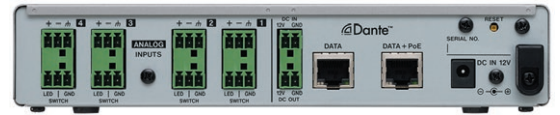

## XLR Model **MM-4D/IN-X** 4-ch Mic/Line Input Dante Converter with built-in DSP Mixer



### Specifications

Audio performance (MIC IN → DANTE OUT)

Mic Amp EIN:	-125dB or less * Input referred noise
Frequency response:	20Hz to 20kHz (Fs=44.1kHz/48kHz) (±0.5dB)
THD (THD+N):	0.003% or less
Signal-to-Noise ratio:	108dBu or higher
Cross talk:	100dBu or higher
Dynamic range:	108dBu or higher
Operating power:	PoE Class0 Optional AC Adapter (PS-S1220E)
Power consumption:	7.5W
Dimensions (WxHxD):	214 x 44.45 x 136.1 mm (inc. protrusions) 253 x 44.45 x 136.1 mm (with bracket)
Weight:	885g
Operating temperature:	0 to 40°C / 32 to 104°F

### Option

- PS-1220E (AC Adapter)
- AK-RS1 (Rack Shelf)

### Series Lineup

- ML-4D/OUT-E (LINE 4 Out, Dante 4x4, Euro Block)
- ML-4D/OUT-X (LINE 4 Out, Dante 4x4, XLR)
- AE-4D (AES/EBU 4 IN, Dante 4x4)
- MM-2D-E (MIC/LINE 2 IN, LINE 2 OUT, Dante 4x4, Euro Block)
- MM-2D-X (MIC/LINE 2 IN, LINE 2 OUT, Dante 4x4, XLR)

### Related Software

- TASCAM DCP CONNECT  
Control software for system integrators/managers that handle the configuration and settings of an entire system, supports Windows, macOS, Android, and iOS.  
(Free download)
- TASCAM EZ CONNECT  
Control software for end-users supports Windows, macOS, Android, and iOS.  
(Free downloads)



### Other features

- Supports Dante Domain Manager, and AES67 Mode
- Mic Pre-amps supporting +48V Phantom Power and Remote Gain Control
- High quality and high performance Mic Pre-amps
- 50 Scene presets triggered by SNTP-based Timer events
- Supports PoE
- Remote control via control software
- Installable according to usage/environment

Please note that not all models and colors are available in every country. Design and specifications subject to change without notice. ©2019 TEAC Corporation. All Rights Reserved. All text, images, graphics and other materials on this brochure are subject to the copyright and other intellectual property rights of TEAC Corporation. These materials shall not directly or indirectly be published, reproduced, modified or distributed in any medium. TEAC and TASCAM are trademarks or registered trademarks of TEAC Corporation. Dante is a trademark of Audinate Pty Ltd. Other brands and product names are trademarks or registered trademarks of respective owners.

Authorized Distributors

# TASCAM®

TEAC CORPORATION

1-47, Ochiai, Tama-shi, Tokyo 206-8530, Japan  
<https://tascam.jp/int>

ISSUED IN JAPAN 1902 D7320